

M90 Tech Tips

SLTS-011 5/2/01

The electrodes are one of the most important components in a fusion splicer. Periodic maintenance of the electrodes is required to insure a stable, consistent arc that will yield a low loss splice. White electrode tips and sizzling sounds are indicators that the electrodes need to be cleaned.

Necessary Tools:

- Electrode hex wrench
- Electrode cleaning tool (p/n 3234001-01) and polishing paper
- Lint free tissues
- Alcohol
- Tweezers

Cleaning the Electrodes

Note: *Electrodes should always be cleaned or replaced as a pair.*

Special Note: *Electrodes are consumable items which are not covered under warranty.*

1. Disconnect the splicer from all power sources and open the electrode flap (Figure 1).
2. Use the electrode hex wrench to loosen the set screws that secure the electrodes by approximately one revolution each (Figure 2).
3. Remove the electrode towards the cleaver by pulling on the black plastic part of the electrode. Close the electrode flap to access the other electrode for removal.
4. Slip a new piece of electrode polishing paper in the electrode cleaning tool with the rough side facing the hole in the cleaning tool (Figure 4).
5. While securing the polishing paper, rotate the electrode several times (Figure 4).
6. Remove the electrode from the tool and clean off the polishing residue with a lint free tissue dampened in alcohol.
7. Replace the electrode in the splicer being sure to insert it completely in the holder. Tighten the set screw with the hex wrench until it is thumb tight.
8. Complete the same procedure for the other electrode.



Warning: *Never operate a fusion splicer with the electrodes removed. Extensive, irreparable damage to the splicer and or personal injury may result.*

All trademarks are the property of their respective holders.

© 2000, 2001 Corning Cable Systems LLC. Please refer to the operating manual provided with the product described above for complete instructions and precautions.

Cleaning Electrodes in Series 5000 and Older M90 Fusion Splicers

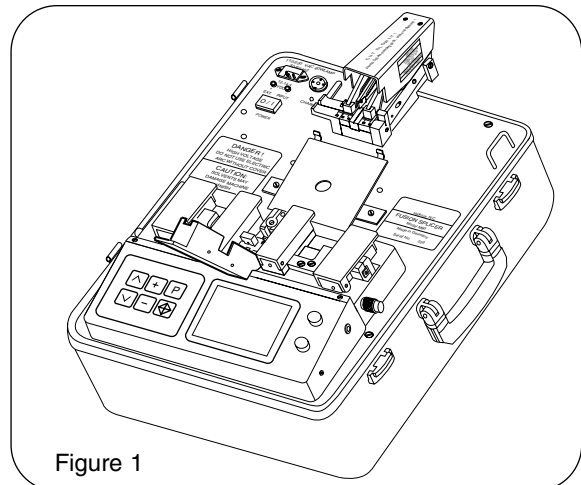

Figure 1

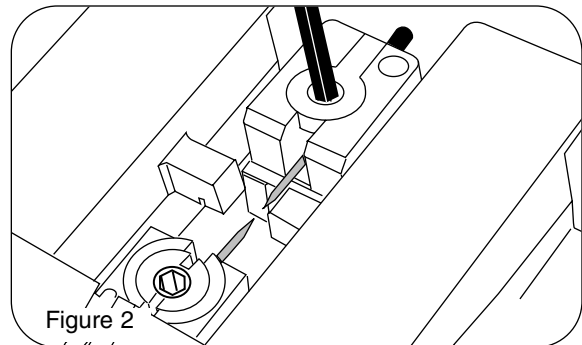

Figure 2

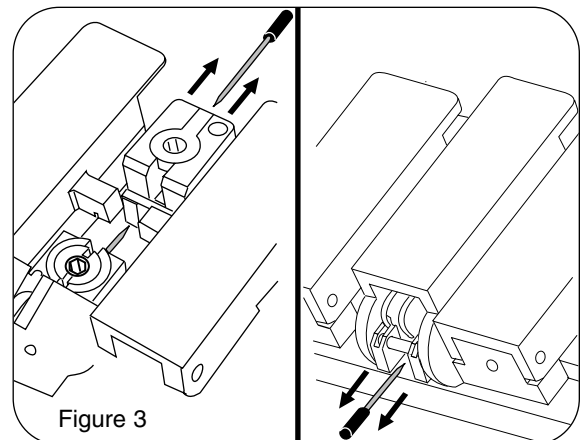

Figure 3

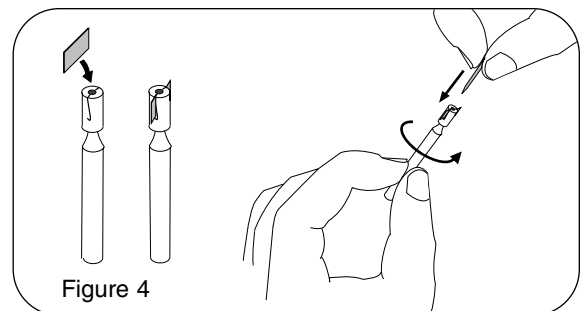

Figure 4